

CLARKE®



WARNING: Read these instructions before using the machine

PETROL DRIVEN POWER WASHER

MODEL NO: TIGER 2500/2900

PART NO: 7320055/7320056

OPERATION & MAINTENANCE INSTRUCTIONS



LS0114

INTRODUCTION

Thank you for purchasing this CLARKE Petrol driven power washer.

Before attempting to use this product, please read this manual thoroughly and follow the instructions carefully. In doing so you will ensure the safety of yourself and that of others around you, and you can look forward to your purchase giving you long and satisfactory service.

GUARANTEE

This product is guaranteed against faulty manufacture for a period of 12 months from the date of purchase. Please keep your receipt which will be required as proof of purchase. This guarantee is invalid if the product is found to have been abused or tampered with in any way, or not used for the purpose for which it was intended.

Faulty goods should be returned to their place of purchase, no product can be returned to us without prior permission.

This guarantee does not effect your statutory rights.

ACCESSORIES

The range of accessories listed below are available from your CLARKE dealer.

ITEM	PART NUMBER
5 Litres Detergent (Traffic Film Remover)	3050821
25 Litres Detergent (Traffic Film Remover)	3050820
5 Litres Wash 'n' Wax	3050815

ENVIRONMENTAL RECYCLING POLICY



Through purchase of this product, the customer is taking on the obligation to deal with the WEEE in accordance with the WEEE regulations in relation to the treatment, recycling & recovery and environmentally sound disposal of the WEEE.

In effect, this means that this product must not be disposed of with general household waste. It must be disposed of according to the laws governing Waste Electrical and Electronic Equipment (WEEE) at a recognised disposal facility.

GENERAL SAFETY RULES



WARNING: Water at high pressure can be dangerous and can cause damage if the operator is careless. Never allow anyone to operate this pressure washer unless they are familiar with the safety precautions.

1. **NEVER** direct the spray towards any person or animal.
2. **NEVER** hold your finger over the high pressure nozzle.
3. **NEVER** allow children or untrained personnel to use this machine.
4. **NEVER** operate the machine with any of the covers removed.
5. **NEVER** attempt any repairs to this machine. Always refer to your Clarke dealer.
6. **NEVER** supply any liquid other than water to the water inlet.
7. **NEVER** use the detergent pickup facility to introduce flammable liquids/solvents, e.g. paint thinners, petrol, oil as there is a risk of explosion.
8. **ALWAYS** release any residual pressure in the system by turning off the water supply and operating the trigger before disconnecting any hose or accessory.
9. **ALWAYS** keep the machine itself dry and well clear of water spray.
10. **ALWAYS** wear protective clothing and safety glasses. Loose particles and other debris may be propelled at high speed by the water jet.
11. **ALWAYS** grip the gun firmly and expect the spray gun to 'kick' when starting.
12. **ALWAYS** respect the requirements of the local water company. Pressure washers may only be connected to the mains drinking water supply if a system separator (also known as a backflow preventer) is installed in the supply hose.
13. **ALWAYS** disconnect from the water supply, and ensure the system is completely drained when not in use. Store in a cool dry location.
14. **ONLY** use chemical cleaning agents (detergents), that are approved for pressure washers. CLARKE Traffic Film Remover or CLARKE Wash and WAX (available from your dealer), is recommended.
15. **WARNING** High pressure water jets can be dangerous if subject to misuse. The jet must not be directed at a person or anything that they are wearing.
16. **NEVER** direct the jet at electrical equipment or the machine itself.
17. **WARNING** High pressure hoses, fittings and couplings are important for the safety of the machine. Use only hoses, fittings and couplings recommended by the manufacturer.
18. **WARNING** Water that has flowed through a system separator (also known as a backflow preventer) is considered non-drinkable.
19. **NEVER** use the pressure washer if the inlet/outlet hoses or important parts of the machine are damaged.

SAFETY SYMBOLS

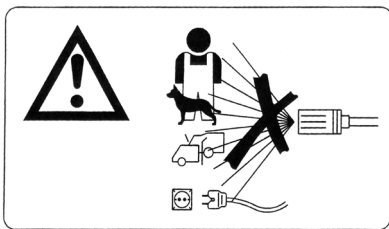

WARNING: Do not direct discharge stream at persons or animals. Keep clear of nozzle.

WARNING: Never direct spray toward any electrical device or electrical outlet.



General Warning, indicates that failing to follow these instruction could result in injury or damage to the machine.



To reduce the risk of injury, read the manual before use.

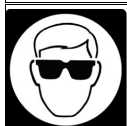

ALWAYS wear safety glasses when using this machine.



DANGER: Risk of fire or explosion. Shut off engine before adding fuel. Keep work area free of combustible materials. Do not spray flammable liquids.



DANGER: Risk to breathing. Engine exhaust fumes can kill. For outdoor use only. Work in a well ventilated area.



WARNING: Risk of injection or severe injury. Do not direct discharge stream at persons or animals. Keep clear of nozzle. This machine is to be used only by qualified operators.



WARNING: Risk of spray injury. Spray can propel objects. Always wear ANSI approved Z87.1 Safety Glasses.



WARNING: Risk of chemical burn. Never spray acids, corrosive or toxic chemicals. Use only cleaners formulated for pressure washers.



WARNING: Risk of electrocution. Never direct spray toward any electrical device or electrical outlet.



WARNING: Risk of unsafe operation. Keep children away from this equipment. Gun kicks back. Hold with both hands.



WARNING: Risk of hot surfaces. Avoid contact with hot engine exhaust components. Don't allow hoses to contact the engine muffler during or after use.

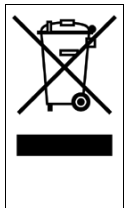

Recycle unwanted materials instead of disposing of them as waste. All tools, accessories and packaging should be sorted, taken to a recycling centre and disposed of in a manner which is compatible with the environment.

OVERVIEW

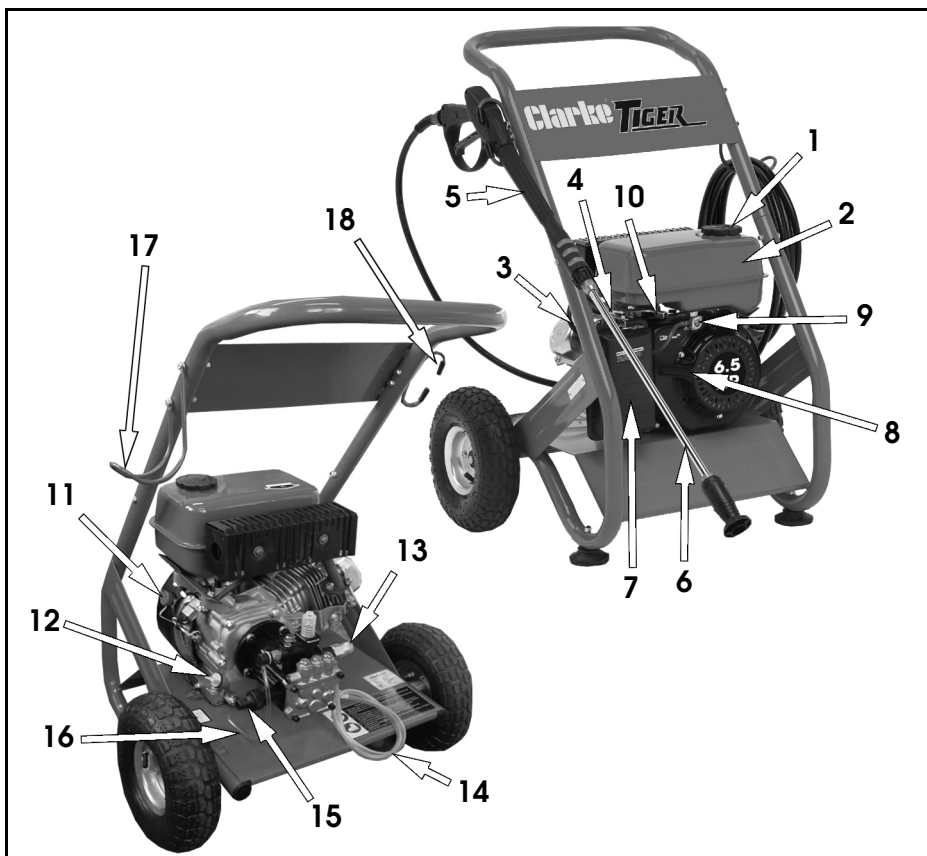

NO	DESCRIPTION	NO	DESCRIPTION
1	Fuel Tank Cap	10	Throttle
2	Fuel Tank	11	Engine On/Off Switch
3	Spark Plug	12	Oil Filler Cap
4	Choke	13	Water Outlet
5	Gun Assembly	14	Detergent Hose
6	Lance	15	Water Inlet
7	Air Filter Cover	16	Bypass Drain Hose
8	Recoil Pull Start	17	Hose Holder
9	Fuel Valve	18	Lance Holder

ASSEMBLY

Unpack your pressure washer and check to ensure the following items are present.

Contact your Clarke dealer immediately if any parts are missing or damaged.

- 1 x Petrol Pressure Washer
- 1 x Hose Holder c/w Fixings
- 1 x Lance Holder c/w Fixings
- 1 x High Pressure Hose
- 1 x Lance Assembly
- 1 x Gun Assembly
- 1 x Spark Plug Box Spanner
- 1 x Tommy Bar
- 2 x Wheel & Axle Assemblies
- 1 x Nozzle Cleaning Pin
- 1 x Tap Adaptor
- 1 x Upper Handle c/w Fixings

CONNECTING THE HANDLE

1. Slide the upper handle into position as shown.
2. Secure using a bolt, 2 washers and a nut on each side.

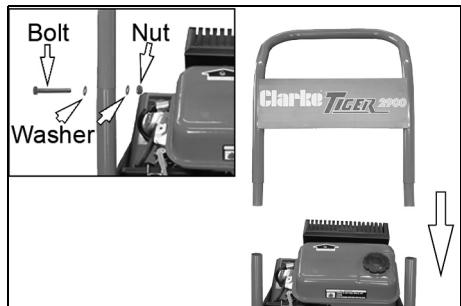

CONNECTING THE WHEELS

1. Slide the axles in to the locating tube as shown
 - Make sure the ball catch locks into the small hole on the bottom of the locating tube.

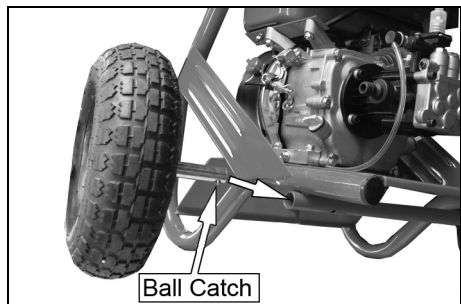

FITTING THE RUBBER FEET

1. Fit the rubber feet to the legs as shown.



FITTING THE LANCE/HOSE HOLDER

1. Fit the holders into the positions shown and secure using the washers and nuts provided.



ASSEMBLING THE LANCE

1. Connect the spray lance to the gun assembly and tighten securely by turning the locking ring.

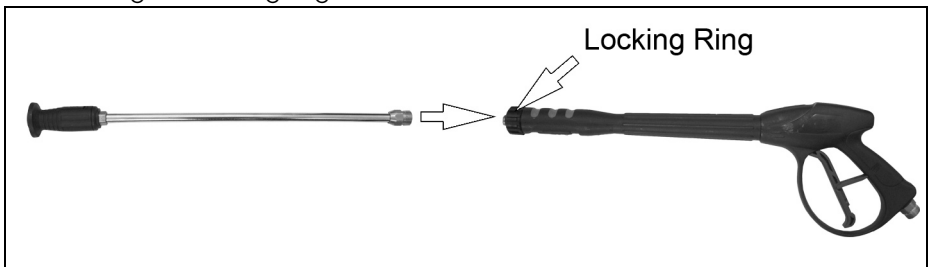

CONNECTING THE HIGH PRESSURE HOSE

CONNECT THE HOSE TO THE GUN

1. Screw the high pressure hose onto the gun assembly.
 - Tighten the connector, hand tight only. Do not use a spanner.

NOTE: Make sure the connection is secure.

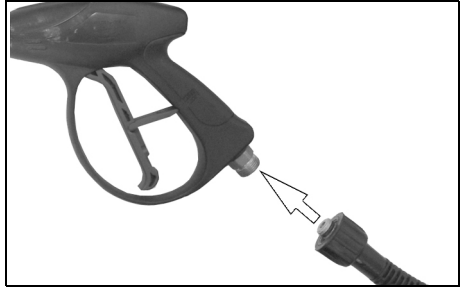

CONNECT THE HOSE TO THE PRESSURE WASHER

1. Screw the hose on to the pressure washer.
 - Tighten the connector, hand tight only, Do not use a spanner.

NOTE: Make sure the connection is secure.

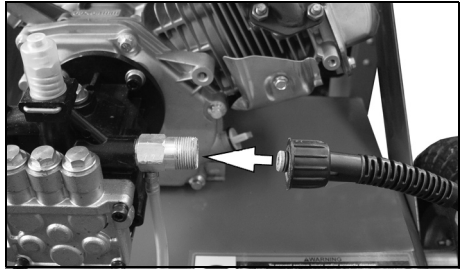

CONNECTING THE WATER SUPPLY

Always follow the regulations of your local water supplier. The pressure washer must never be connected to the drinking water supply without using a system separator (also known as a backflow preventer) available from most hardware stores.

NOTE: Water that has flowed through a system separator is considered non-drinkable.

1. Connect a water supply hose (not supplied) to the water inlet.

NOTE: Use a good quality fibre-reinforced water hose with a standard coupling.

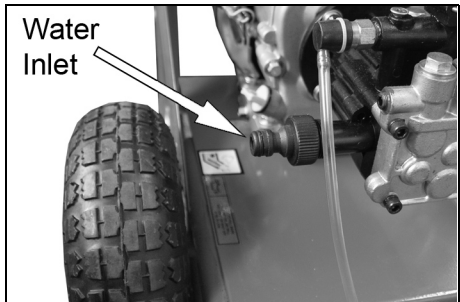

BEFORE USE



WARNING: TO CARRY OUT THIS CHECK, PLACE THE PRESSURE WASHER ON LEVEL GROUND WITH THE ENGINE SWITCHED OFF.

WARNING: TAKE CARE NOT TO TOUCH ANY HOT PARTS OF THE PRESSURE WASHER WHEN CHECKING THE OIL LEVEL.

IMPORTANT: *The engine is supplied without any oil in it and must be filled to the correct level before use, see below.*

ENGINE OIL

1. Turn the oil filler cap anticlockwise and remove it from the engine, wipe the integral dipstick with a clean cloth.

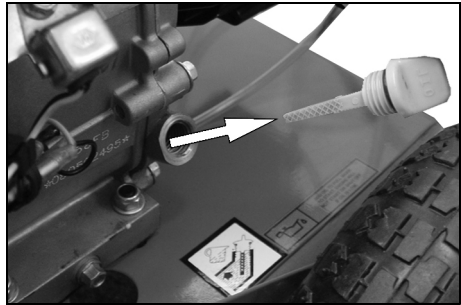

2. Insert the oil filler cap back into place and then remove it again.
3. If the oil reads low on the dipstick, add oil to the oil reservoir (Max 0.4L).
 - We recommend the use of SAE10W-30 oil.
 - Do not overfill the oil reservoir.
4. Replace the oil filler cap.

NOTE: Running the engine with insufficient oil will cause engine damage.

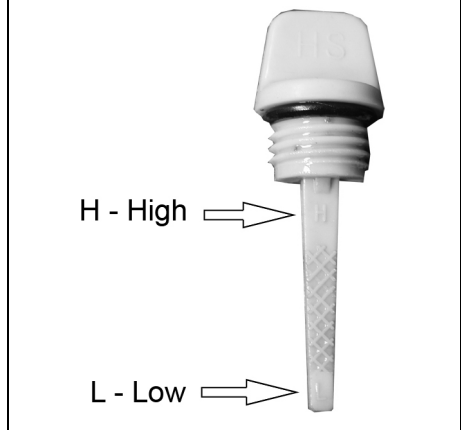

FUEL

- Refuel in a well-ventilated area, away from any sources of ignition.
- If the engine has been running, allow it to cool before refueling.
- Do not leave fuel within the reach of children.
- Refuel carefully to avoid spilling fuel.

1. Remove the fuel tank cap.

- Just inside the fuel tank is a fuel strainer, which should be checked periodically and any contaminants which have accumulated must be removed.

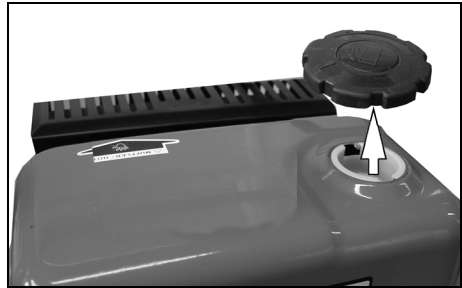

2. Pour unleaded petrol through the fuel strainer and into the fuel tank

- Do not fill above the fuel strainer shoulder.
- Use unleaded petrol with a pump octane rating of 86 or higher.

MAXIMUM FUEL LEVEL

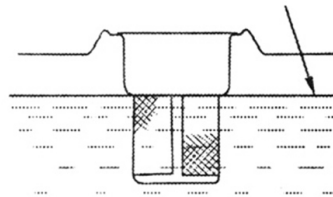

3. Replace the fuel filler cap securely.

STARTING YOUR PRESSURE WASHER

1. Turn the water supply on, making sure that the tap is fully open.



WARNING: FAILURE TO TURN ON THE WATER COULD CAUSE DAMAGE TO THE PRESSURE WASHER.

2. Set the choke lever to the START position.



3. Set the fuel supply valve to the open position.

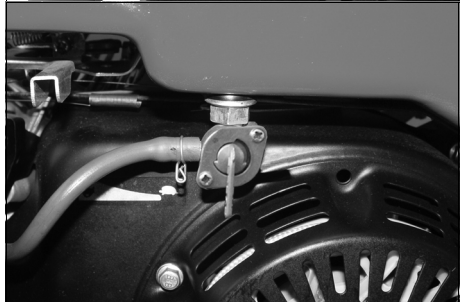

4. Slide the throttle lever to the left approximately 3/4 of the way.

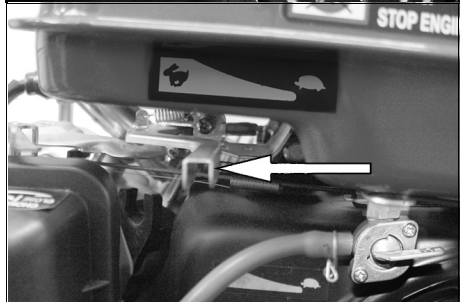

5. Set the engine switch to the on (I) position

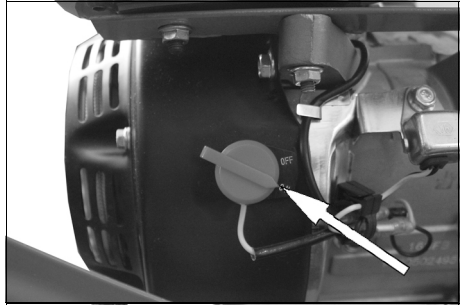

6. Pull the recoil starting handle lightly until you start to feel resistance and then pull up sharply to start the engine.

- You may have to do this more than once.



WARNING: ONCE THE PRESSURE WASHER ENGINE HAS STARTED, RELEASE THE STARTING HANDLE SLOWLY TO AVOID INJURY/DAMAGE AS IT RECOILS.

7. Slide the choke lever to the RUN position.

- The pressure washer is now ready for use.

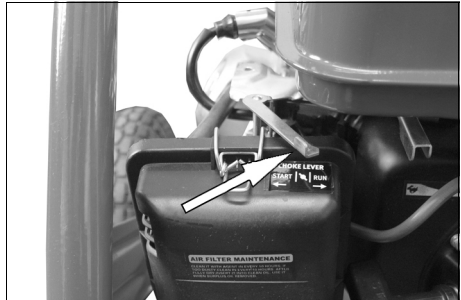

8. Release the trigger lock.

9. Ensuring that you have a firm footing and that you are also holding the gun assembly and spray lance firmly, pull the trigger on the gun to start water flow.

- The lance and gun will kick back when the trigger is first pulled.

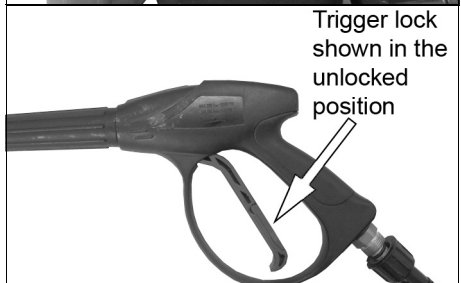

INTERRUPTING OPERATION

1. Release the trigger.

NOTE: The pressure washer will automatically go into bypass mode.



WARNING: DO NOT ALLOW THE UNIT TO OPERATE IN BYPASS MODE FOR MORE THEN TWO MINUTES AT ANY TIME. TURN THE UNIT OFF IF IT IS NOT GOING TO BE USED FOR A PERIOD LONGER THAN THIS. SEE PAGE 14.

NOTE: If you notice water coming from the drain tube attached to the pump, please note that this is a safety feature and should be expected, it cools the pump by releasing some of the hot water within the pump and replacing it with fresh 'cool' water.

2. Rotate the trigger lock to the locked position.



ADJUSTING THE SPRAY NOZZLE

The nozzle is adjustable to allow you to adjust the water delivery from a narrow jet of water to a wide spray. To adjust the nozzle, proceed as follows:

1. Hold the shaft of the lance in one hand.
2. Twist the nozzle with the other hand.
 - The spray varies between narrow and wide as you turn the nozzle.



ADJUSTING THE PRESSURE

The machine output is preset at the factory. To lower the contact pressure:

1. Back away from the surface to be cleaned. The further away you are the less the pressure will be on the surface being cleaned.
2. Reduce the speed of the engine using the throttle. Slow the engine down and the water pressure will also go down.
3. Adjust the spray to a wider angle.
4. Hold the rear of the nozzle and slide the front of the nozzle forwards to low pressure and backwards for high pressure.

APPLYING DETERGENTS AND CLEANING AGENTS

To improve the cleaning performance, you can introduce chemical cleaning agents (detergents) to the water jet using the detergent pickup hose.

1. Place the detergent pickup hose into a container holding the chemical/cleaning solution.
 - Only use detergents recommended for use with pressure washers, such as CLARKE Traffic Film Remover which is a powerful low foaming agent for car cleaning, patio cleaning etc., or CLARKE Wash & Wax, both available from your CLARKE dealer.
2. Hold the rear of the nozzle on the high pressure lance and slide the front of the nozzle forwards to low pressure.
3. Spray the detergent onto the vehicle, patio etc.
 - Allow the detergent a little time to work itself into the grime.

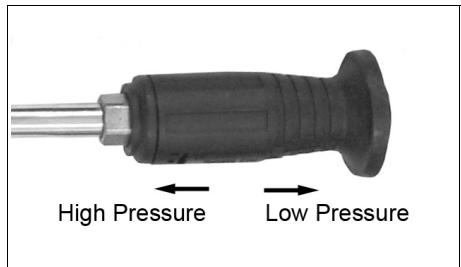
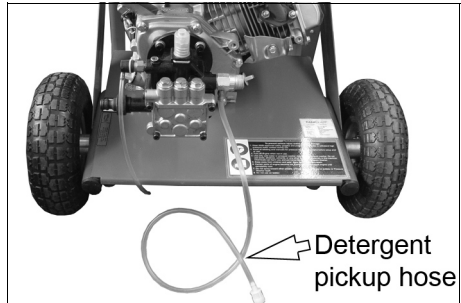

CAUTION: IF YOUR EYES COME INTO CONTACT WITH ANY CLEANING FLUIDS, RINSE THEM IMMEDIATELY WITH PLENTY OF FRESH CLEAN WATER, AND SEEK MEDICAL ADVICE IF REQUIRED.

4. To rinse, remove the detergent pickup hose from the container holding chemical/cleaning solution, slide the front of the nozzle on the lance back towards the handle and use the pressure washer as normal.

SHUTTING DOWN

1. After each use, if you have applied chemicals, place detergent pickup hose into a container of clean water and run clean water through detergent pickup hose to flush the system thoroughly.
2. Move the throttle control lever to the right.

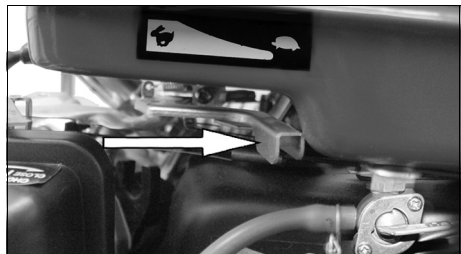

3. Turn off the engine switch, to the off (0) position.
4. Turn water supply off at the tap.
5. NEVER turn the water off with the engine running.
6. Release the pressure in the pump and hose by squeezing the trigger for a few seconds until no more water comes out of the nozzle.
7. Turn the fuel supply valve to the closed position.

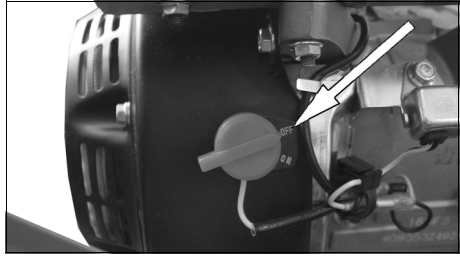

8. Rotate the trigger lock to the locked position.

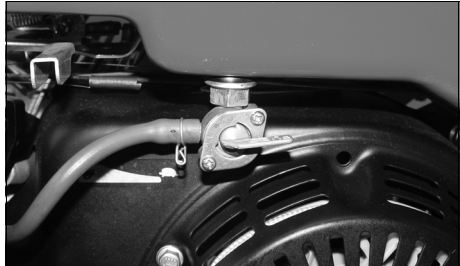

STORAGE

BEFORE STORING THE PRESSURE WASHER

1. Disconnect the high pressure hose and drain all water from the hose.
2. Coil the hose and store the lance/hose in their respective holders located on either side of the pressure washer.

STORAGE PROCEDURE

Make sure that the pressure washer has been thoroughly cleaned before storing it in a clean dry place. See "Maintenance" on page 16.

For long term storage See page 18.

MAINTENANCE

CLEANING THE NOZZLE

1. Shut off the pressure washer and turn off the water supply.
2. Pull trigger on the gun handle to release any water pressure.
3. Disconnect the lance from the gun assembly.
4. Remove any obstructions with the nozzle cleaning tool provided and back flush with clean water.
5. Direct water supply into the end of the lance for 30 seconds to back flush loosened particles.
6. Reconnect the lance to the gun assembly and turn on the water supply.

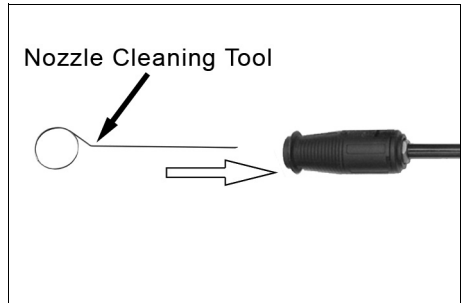

CLEANING THE WATER INLET FILTER

This screen filter should be checked periodically and cleaned if necessary.

1. Remove filter from the water inlet of the pump as shown.
2. Clean filter by flushing both sides with water.
3. Replace the filter into the water inlet.
 - Do not operate pressure washer without filter properly installed.

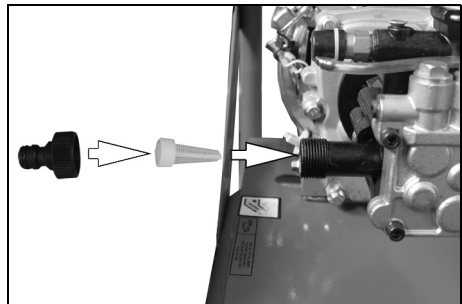

CLEANING THE FUEL STRAINER

Just inside the fuel tank is a fuel strainer, check this periodically and remove any contaminants which may have accumulated.

1. Open the fuel tank cap.
2. Remove the fuel strainer.
3. Remove any contaminants.
4. Replace the fuel strainer.
 - Do not operate pressure washer without fuel strainer properly installed.

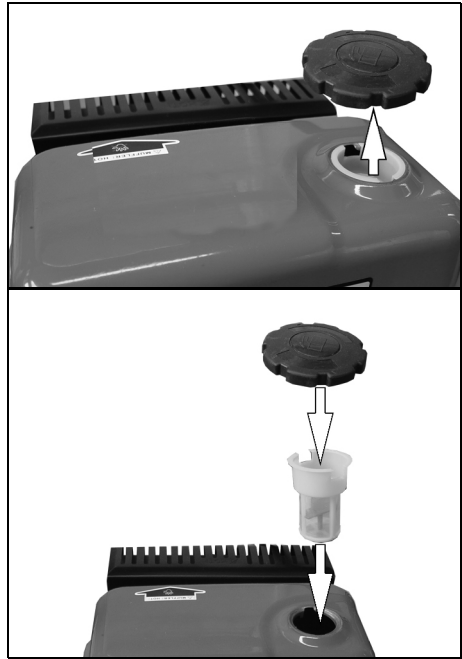

CLEANING THE AIR FILTER

1. Release the two clips on the air filter cover.
2. Remove the air filter cover.
3. Remove the air filter elements.
4. Wash the elements in a solution of warm water and mild detergent.



WARNING: DO NOT USE FLAMMABLE SOLVENTS OR PETROL TO CLEAN THE AIR FILTER

5. Rinse thoroughly and leave the elements to dry. Once it is completely dry, immerse the filter in clean engine oil and squeeze to remove excess oil.
 - If the air filter is damaged contact Clarke spare parts department for a replacement.
 - Replace the filter into its original position and refit the air filter cover.

CHANGING THE SPARK PLUGS



CAUTION: ALLOW THE ENGINE TO COOL BEFORE REMOVING THE SPARK PLUG.

1. Remove the spark plug cap from the spark plug.
2. Use the spark plug spanner supplied to remove the spark plug.
3. Remove any carbon that has accumulated around the sparkplug.
4. Check the spark plug gap (a), it should be between 0.7 and 0.8 mm, adjust if necessary.
5. Check the overall condition of the spark plug and replace if necessary.
6. Reinstall the spark plug and replace the spark plug cap.

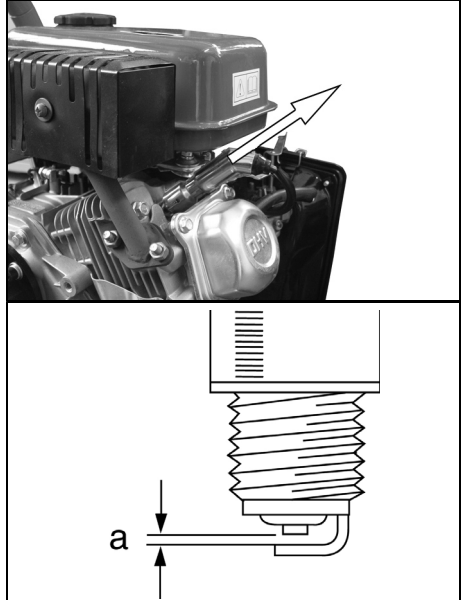

LONG TERM STORAGE

For long term storage,

1. The petrol tank should be drained.
 - Ensure that the engine is cold before draining the tank.
2. Remove the fuel tank cap and use a pump type syphon to drain the petrol into an appropriate, clean container.
 - Do not store petrol for long periods of time.
 - Dispose of excess petrol in an environmentally safe way. Your local recycling centre can advise you on the best method of disposal.
3. After the petrol tank has been drained, start the engine and allow it to use any petrol that may remain in the engine, or fuel pipe.
4. Make sure that the power washer has been thoroughly cleaned before storing it in a clean dry place.

TROUBLESHOOTING

If the following does not solve your problem, please contact the CLARKE service department.

PROBLEM	CAUSE	SOLUTION
Engine will not start (see engine manual for further engine troubleshooting)	No fuel.	Add fuel.
	Low oil.	Add oil.
	Pressure builds up after two pulls on the recoil starter or after initial use.	Squeeze the gun trigger to relieve the pressure.
	Spark plug lead not attached securely.	Attach the spark plug lead.
	Engine switch is in the OFF position.	Set the engine switch to the ON position.
	Choke lever is set to the ON position when the engine is already warm.	Set the choke lever to the OFF (right) position.
	Fuel valve closed.	Open the fuel valve.
Lack of pressure (initial use)	Leak in the high pressure hose fitting.	Tighten the fitting, use sealant tape if required.
	Nozzle is obstructed.	Clear the nozzle.
	Water filter screen is clogged.	Remove and clean the filter.
	Air in the hose.	Turn off the engine. Turn off the water supply. Disconnect the water source from the pump inlet and turn on the water source to expel the air from the hose. When all the air has been removed, turn off the water supply and reconnect the hose. Turn on the water supply and pull the trigger to expel any air in the gun/lance.

PROBLEM	CAUSE	SOLUTION
Lack of pressure (initial use) continued	Choke lever is in the OPEN position.	Set the choke lever to the OFF (right) position.
	Throttle control lever is not set high enough.	Move the throttle control lever to left.
	High pressure hose is too long.	Make sure the high pressure hose is under 100 feet.
Will not draw chemicals	Chemical filter is blocked.	Clean the filter.
	Chemicals being used are too thick.	Dilute the chemicals. The chemicals should have the consistency of water.
	High pressure hose is too long.	Use a longer supply hose instead of a very long high pressure hose.
	Chemical build up inside the chemical injector.	Have the parts cleaned or replaced by your dealer.
Lack of pressure (after a period of normal use)	Worn seal or packing.	Have them replaced by your dealer.
	Worn or obstructed valves.	Have them replaced by your dealer.
Water leaking at the pump	Loose connections.	Tighten.
	Worn or broken O-rings.	Have them replaced by your dealer.
	Pump head or tubes damaged from freezing.	Have it replaced by your dealer. See "Storage" on page 15.
Oil leaking at the pump	Oil seals worn.	Have them replaced by your dealer.
	Worn O-rings.	Check and replace.
Water leaking from the drain hose	Pump is overheating	This is a safety feature and should be expected, it cools the pump by releasing some of the hot water within the pump and replacing it with fresh 'cool' water.
Pump pulsates	Nozzle obstructed.	Clear the nozzle.

SPECIFICATIONS

MODEL NO	TIGER 2500	TIGER 2900
ENGINE		
Engine type	Petrol (unleaded), OHV Single Cylinder 4 stroke forced air cooling	Petrol (unleaded), OHV Single Cylinder 4 stroke forced air cooling
Capacity/displacement:	118 cc	196 cc
Oil Capacity	0.6 L	0.6 L
Lubrication Grade	SAE10W-30	SAE10W-30
Fuel Tank Capacity:(Litres)	2.1 Litres	4 Litres
WATER CONNECTION		
Max. Feed Temperature	50 °C	50 °C
Max. Feed Pressure	3-6 Bar	3-6 Bar
PERFORMANCE DATA		
Maximum Pump Pressure	170 Bar	200 Bar
Working Pressure	130 Bar	150 Bar
Maximum Water Flow	7 l/min	8 l/min
NOISE & VIBRATION		
Sound Power Level LWA	103 dB(A)	105 dB(A)
Guaranteed Sound Power Level LWA	105 dB(A)	108 dB(A)
Uncertainty Factor K	2.16	2.79
Vibration	4.494 m/s	3.398 m/s
Uncertainty Factor K	1.5	1.5
DIMENSIONS		
Length	465 mm	565 mm
Width	560 mm	668 mm
Height	750 mm	877 mm
Weight	31.7 kg	34.7 kg

EXPLODED DIAGRAM (TIGER 2500)

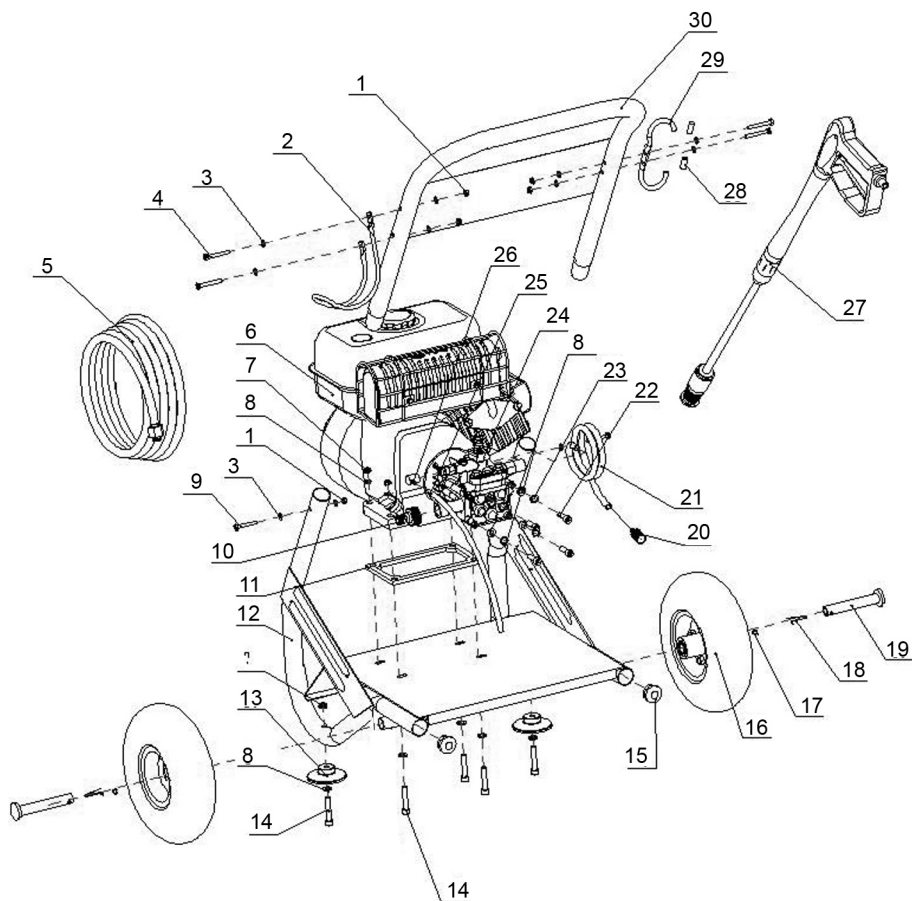

WARNING: TO ENSURE MACHINE SAFETY, USE ONLY ORIGINAL SPARE PARTS FROM CLARKE INTERNATIONAL.

PARTS LIST (TIGER 2500)

NO	DESCRIPTION	PART NO
1	Locknut M5	RKTIG250001
2	Hose Holder	RKTIG250002
3	Gasket	RKTIG250003
4	Hex Bolt M5x40	RKTIG250004
5	High Pressure Hose	RKTIG250005
6	4.0hp Engine	RKTIG250006
7	Locknut M8	RKTIG250007
8	Gasket	RKTIG250008
9	Hex Bolt M5x35	RKTIG250009
10	Inlet Connector	RKTIG250010
11	Isolator	RKTIG250011
12	Frame	RKTIG250012
13	Rubber Foot	RKTIG250013
14	Inner Hex Bolt M8*40	RKTIG250014
15	Rubber Plug	RKTIG250015
16	8" Solid Wheel	RKTIG250016
17	Wheel Shaft Circlip	RKTIG250017
18	Spring Wire	RKTIG250018
19	Wheel Axle	RKTIG250019
20	Detergent Filter	RKTIG250020
21	Detergent Hose	RKTIG250021
22	Inner Hex Bolt M8*25	RKTIG250022
23	Spring Gasket	RKTIG250023
24	High Pressure Pump	RKTIG250024
25	Drain Pipe	RKTIG250025
26	Thermal Relief Cap	RKTIG250026
27	High Pressure Gun	RKTIG250027
28	Gun Holder Sleeve	RKTIG250028
29	Gun Holder	RKTIG250029
30	Handle	RKTIG250030

EXPLODED DIAGRAM (TIGER 2900)

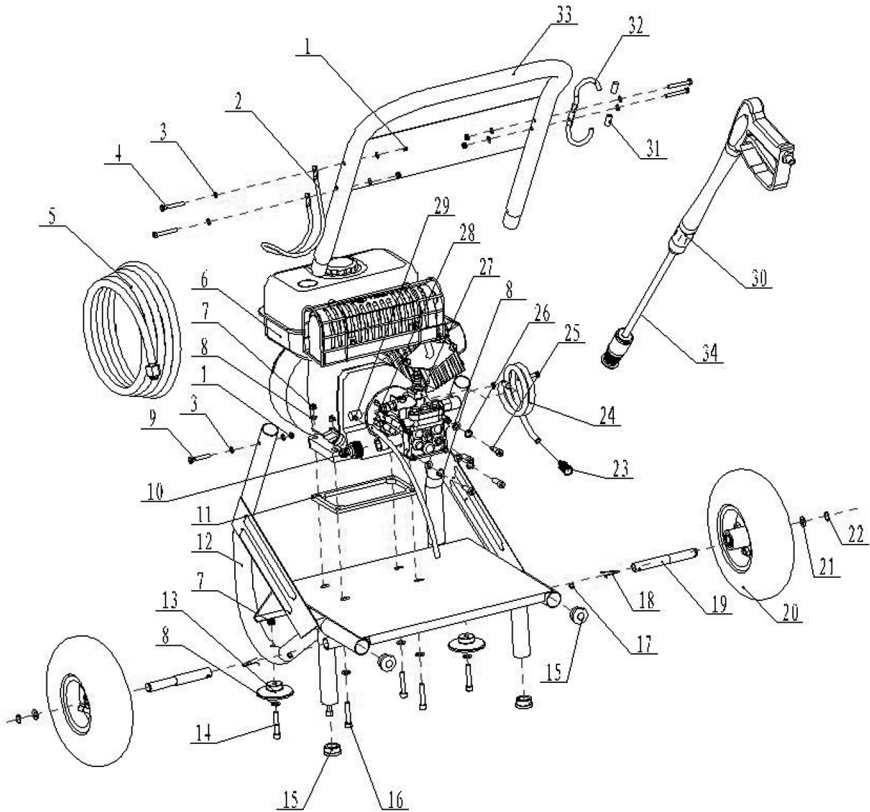

WARNING: TO ENSURE MACHINE SAFETY, USE ONLY ORIGINAL SPARE PARTS FROM CLARKE INTERNATIONAL.

PARTS LIST (TIGER 2900)

NO	DESCRIPTION	PART NO
1	Locknut M6	RKTIG290001
2	Hose Holder	RKTIG290002
3	Washer	RKTIG290003
4	Hex Bolt M6x45	RKTIG290004
5	High Pressure Hose	RKTIG290005
6	6.5hp Engine	RKTIG290006
7	Locknut M8	RKTIG290007
8	Washer	RKTIG290008
9	Hex Bolt M6x40	RKTIG290009
10	Inlet Connector	RKTIG290010
11	Mounting pad	RKTIG290011
12	Frame	RKTIG290012
13	Rubber Foot	RKTIG290013
14	Hex Bolt M8x45	RKTIG290014
15	Rubber Plug	RKTIG290015
16	Hex Bolt M8x40	RKTIG290016
17	Wheel Shaft Clip	RKTIG290017
18	Spring Wire	RKTIG290018
19	Wheel Axle	RKTIG290019
20	10" Wheel	RKTIG290020
21	Washer	RKTIG290021
22	Circlip	RKTIG290022
23	Detergent Filter	RKTIG290023
24	Detergent Hose	RKTIG290024
25	Hex Bolt M8x25	RKTIG290025
26	Spring Washer	RKTIG290026
27	High Pressure Pump	RKTIG290027
28	Drain Tube	RKTIG290028
29	Thermal Relief Cap	RKTIG290029
30	High Pressure Gun	RKTIG290030
31	Gun Holder Sleeve	RKTIG290031
32	Gun Holder	RKTIG290032
33	Handle	RKTIG290033
34	Lance	RKTIG290034

DECLARATION OF CONFORMITY TIGER 2500



Clarke[®]
INTERNATIONAL

Hemncall Street, Epping, Essex CM16 4LG

DECLARATION OF CONFORMITY

This is an important document and should be retained.

Product Description: Power Washer

Model number(s): Tiger 2500

Serial / batch Number: 7320055

Date of Issue: 16/07/2010

(Noise Conformity)

Notified Body: TÜV SÜD Industrie GmmH
Westendstraße 199
80686 MÜNCHEN
Germany

Technical Documentation Holder: A.R. Pond
Clarke International
2a Shrubland Road
London E10,7RB
UK

Conformity Assessment Procedure: to 2000/14/EC Annex V

Manufacturer: Clarke International

Noise Related Value: 420 l/h

Measured Sound Power Level: 103dB

Guaranteed Sound Power Level: 105dB

DECLARATION OF CONFORMITY TIGER 2500



Clarke[®]
INTERNATIONAL

Hemncill Street, Epping, Essex CM16 4LG

DECLARATION OF CONFORMITY

This is an important document and should be retained.

We hereby declare that this product(s) complies with the following directive(s):

- 2004/108/EC *Electromagnetic Compatibility Directive.*
- 2006/42/EC *Machinery Directive.*
- 2006/95/EC *Low Voltage Equipment Directive.*
- 2002/95/EC *Restriction of Hazardous substances.*
- 2000/14/EC *Noise Emissions Directive, (amended by 2005/88/EC).*
- 97/68/EC *Emission of Gaseous and Particulate Pollutants for Internal Combustion Engines to be installed in Non-road Mobile Machinery, (amended by 2004/26/EC)*

The following standards have been applied to the product(s):

prEN 1828-1:2007, EN 55012+A1:2005, EN61000-6-1:2007

The technical documentation required to demonstrate that the product(s) meet(s) the requirement(s) of the aforementioned directive(s) has been compiled and is available for inspection by the relevant enforcement authorities.

The CE mark was first applied in: 2008

Signed:

J.A. Clarke
Director

DECLARATION OF CONFORMITY TIGER 2900



Clarke[®]
INTERNATIONAL

Hemnal Street, Epping, Essex CM16 4LG

DECLARATION OF CONFORMITY

This is an important document and should be retained.

Product Description: Power Washer
Model number(s): Tiger 2900
Serial / batch Number: 7320056
Date of Issue: 16/07/2010
(Noise Conformity)
Notified Body: TÜV SÜD Industrie GmmH
Westendstraße 199
80686 MÜNCHEN
Germany

Technical Documentation Holder: A.R. Pond
Clarke International
2a Shrubland Road
London E10,7RB
UK

Conformity Assessment Procedure: to 2000/14/EC Annex V
Manufacturer: Clarke International
Noise Related Value: 480 l/h
Measured Sound Power Level: 105dB
Guaranteed Sound Power Level: 108dB

DECLARATION OF CONFORMITY TIGER 2900



Clarke[®]
INTERNATIONAL

Hemnal Street, Epping, Essex CM16 4LG

DECLARATION OF CONFORMITY

This is an important document and should be retained.

We hereby declare that this product(s) complies with the following directive(s):

- 2004/108/EC Electromagnetic Compatibility Directive.*
- 2006/42/EC Machinery Directive.*
- 2006/95/EC Low Voltage Equipment Directive.*
- 2002/95/EC Restriction of Hazardous substances.*
- 2000/14/EC Noise Emissions Directive, (amended by 2005/88/EC).*
- 97/68/EC Emission of Gaseous and Particulate Pollutants for Internal Combustion Engines to be installed in Non-road Mobile Machinery, (amended by 2004/26/EC)*

The following standards have been applied to the product(s):

prEN 1828-1:2007, EN 55012+A1:2005, EN61000-6-1:2007

The technical documentation required to demonstrate that the product(s) meet(s) the requirement(s) of the aforementioned directive(s) has been compiled and is available for inspection by the relevant enforcement authorities.

The CE mark was first applied in: 2008

Signed:



J.A. Clarke
Director

NOTES

NOTES

A SELECTION FROM THE VAST RANGE OF

Clarke®

QUALITY PRODUCTS

AIR COMPRESSORS

From DIY to industrial, Plus air tools, spray guns and accessories.

GENERATORS

Prime duty or emergency standby for business, home and leisure.

POWER WASHERS

Hot and cold, electric and engine driven - we have what you need

WELDERS

Mig, Arc, Tig and Spot. From DIY to auto/industrial.

METALWORKING

Drills, grinders and saws for DIY and professional use.

WOODWORKING

Saws, sanders, lathes, mortisers and dust extraction.

HYDRAULICS

Cranes, body repair kits, transmission jacks for all types of workshop use.

WATER PUMPS

Submersible, electric and engine driven for DIY, agriculture and industry.

POWER TOOLS

Angle grinders, cordless drill sets, saws and sanders.

STARTERS/CHARGERS

All sizes for car and commercial use.



PARTS & SERVICE: 020 8988 7400

E-mail: Parts@clarkeinternational.com or Service@clarkeinternational.com

SALES: UK 01992 565333 or Export 00 44 (0)1992 565335

Clarke® INTERNATIONAL Hemnall Street, Epping, Essex CM16 4LG
www.clarkeinternational.com